

MAX-SERIES™

RS-75

**BUILT FOR
COMFORT.
ENGINEERED
FOR SPEED.**



The radial-lift RS-75 MAX-Series™ skid steer is built with excellent operating capacity, horsepower and ground clearance for its size class. That means the RS-75 is able to load more material faster without slowing down to get more work done no matter the conditions. And with MAX-Series cab features—like premium 360-degree visibility, a state-of-the-art control panel and more room than ever—operators will experience comfort and productivity like never before.

// HIGH-SPEED PERFORMANCE / PREMIUM CAB / INCREDIBLE PRODUCTIVITY

asv

MAX-SERIES™

RS-75 SKID STEER

OPERATING SPECIFICATIONS	
LOADER ARMS	Radial
OPERATING WEIGHT	7,595 lbs (3,454 kg)
SHIPPING WEIGHT	6,780 lbs (3,318 kg)
OPERATING CAPACITY (50% of tipping load)	2,600 lbs (1,179 kg)
TIPPING LOAD	5,200 lbs (2,358 kg)
TRAVEL SPEED, MAXIMUM- 1 ST SPEED	8.1 mph (13 kph)
TRAVEL SPEED, MAXIMUM- 2 ND SPEED	11 mph (17.7 kph)
BREAKOUT FORCE AT BUCKET EDGE	5,845 lbs (2,651 kg)
GROUND CLEARANCE	10.4 in. (264.2 mm)
WIDTH OVER TIRES	72 in. (1,829 mm)
WIDTH OVER TIRES WITH RIMS REVERSED	66 in. (1,676 mm)
ENGINE	
TYPE	Diesel, 4-cylinder, turbocharged
MODEL	Deutz TCD 2.9 L4
DISPLACEMENT	177 in. ³ (2.9 L)
GROSS POWER RATING AT 2600 RPM	74 hp (55 kW)
TORQUE, PEAK	192 ft-lb (260 Nm)
COOLING SYSTEM	Engine-driven fan and coolant/anti-freeze-filled radiator
INTAKE AIR CLEANER	Dual stage
EMISSION CONTROLS	Meets all U.S. EPA Tier 4 final standards
DRIVE TRAIN	
DRIVE SYSTEM	Hydrostatic
CHAIN CASE	Bow tie drive system
CHAIN SIZE	100 ANSI chain
WHEEL SIZE	12 x 16.5
TRACTIVE EFFORT	8,546 lbs (3,876.4 kg)

* Machine tested with foundry bucket

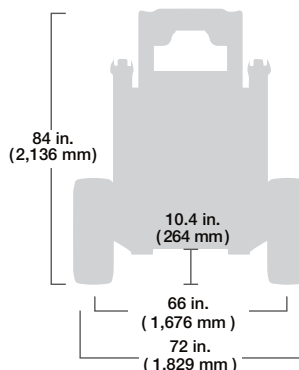
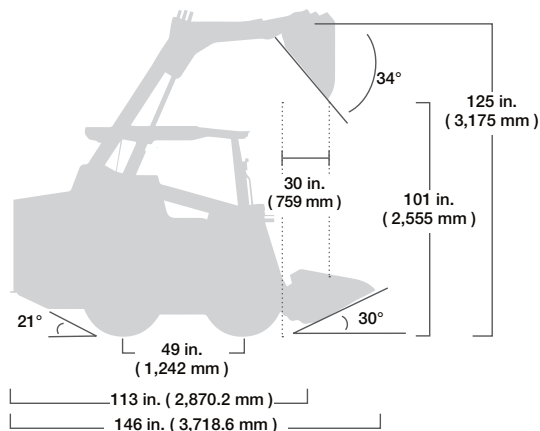

AUXILIARY HYDRAULIC SYSTEM	
STANDARD PUMP CAPACITY	21.3 gpm (80.6 lpm) Optional: 30.9 gpm (117 lpm)
SYSTEM PRESSURE, MAX.	3,335 psi (230 bar)
CONTROLS	Variable flow via joystick button or continuous via console switch, mode selectable via dash-mounted switch
COUPLERS	Push-to-connect quick couplers mounted on loader arms. Pressure relief valve mounted to coupler block
COOLING SYSTEM	High efficiency side-by-side radiator and oil cooler
ELECTRICAL SYSTEM	
NOMINAL CHARGE	12 V
BATTERY	800 CCA
CHARGING SYSTEM	95 amp alternator
OUTLETS	1-12 V port inside operator station
WIRING	Pre-wired for all factory-available accessories
OPERATOR STATION	
SEAT: Vinyl seat with built in operator presence switch, Operator Manual pouch, and 2 in (51 mm) wide seat belt, adjustable position seat optional	
LOADER CONTROL: Right-hand pilot hydraulic joystick controls loader lift, lower and tilt, plus variable control of auxiliary hydraulic.	
DRIVE CONTROL: Left-hand pilot hydraulic joystick controls machine speed and direction.	
ENGINE SPEED	Hand-operated dial, foot throttle optional.
MACHINE DISPLAY: Engine RPM, engine oil pressure, hydraulic oil high temperature, engine coolant temperature, battery voltage, hourmeter, fuel level, trip meter, engine diagnostics, system monitoring, fault logging. Deluxe includes: 7" color touch screen, integrated rear view camera, password protection with user profiles, job clock, maintenance schedules	
ROPS	Restraint-ISO 6683, SAE J2292, Cal OSHA 1596, ISO 3471
FOPS	Meets ISO 3449: Level I and II (Optional)
ILLUMINATION	2 - Fixed forward-facing halogen lights 2 - Adjustable rear-facing halogen light 2 - LED Side lights (optional) 1 - Interior light
CONVENIENCE	12 V power port
STANDARD FEATURES	Horn, backup alarm, cupholder, phoneholder, behind seat storage, rear view mirror, lapbar, roof escape hatch, roof panel & rear cab windows. Premium Features: Adjustable joystick & arm rest positions, adjustable directional & air flow HVAC vents, radio with bluetooth & USB, frameless front door, attachment control kit, wiper/washer, beacon switch/outlet, easy-off door