

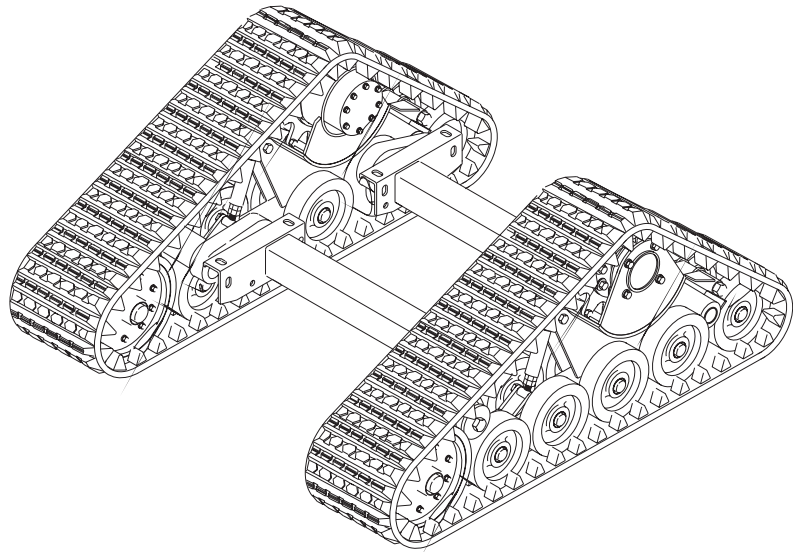

RT•50 Undercarriage Specifications

Rubber Track Undercarriage with Suspension

6,000 lb/2722 kg GVWR
with Direct Drive



Description:

The ASV RT•50 is a patent-pending undercarriage with 15 in./381 mm wide rubber tracks and rubber torsion dual axle suspension. This undercarriage was originally designed for ASV's RC•50 (below) and R•50 All Surface Loaders. The same undercarriage is also used on Caterpillar's 247 and 257 Multi Terrain Loaders. This undercarriage is now available to original equipment manufacturers for application on equipment with up to 6,000 lb/2722 kg gross vehicle weight.

The RT•50 features a durable and field-proven rubber track. The track is constructed using a proprietary process which molds a durable rubber compound around high-tensile strength cords that prevent track stretch. Low-profile grousers are molded into the track.

The undercarriage spreads the machine weight over a wide ground surface area to provide high flotation, optimum traction and smooth operation. It is ideal for applications where relatively fast machine speeds, excellent rimpull and low ground pressure are desired.



RT•50 Undercarriage on on
Caterpillar 257 Multi
Terrain Loader



The undercarriage features an internal positive drive system. A direct-drive, low-speed/high-torque hydrostatic motor on each side drives an elevated drive sprocket. Roller sleeves on the drive sprocket mesh with a row of sturdy rubber lugs on the inside of the track for smooth, low-noise operation. A row of lugs on the outside edge of the rubber track help assure proper track alignment and prevents flexing at the edge.

The undercarriage drive system will handle up to 50 hp/37.3 kW input and maximum continuous hydraulic pressure of 3000 psi/20 670 kPa.

The RT•50 uses only rubber-on-rubber contact points between the track and undercarriage components. This minimizes component wear and makes for smooth, quiet operation.

Twenty-four rubber wheels within the undercarriage spread machine weight over a large ground contact area and span the rubber track from edge to edge. In an application with a 5,000 lb/2268 kg GVW, the ground pressure would be only 2.8 psi/19.3 kPa.

Two rubber torsion axles provide suspension for the undercarriage system. Suspension softens impacts, not only to the undercarriage as it travels over rough and uneven surfaces but also reduces vibration and impact to the machine. The result is smooth and comfortable operation which extends undercarriage and machine life and increases operator satisfaction. For material handling applications, the suspension helps increase material retention.

The RT•50 is a very low maintenance undercarriage. Track tension adjustments are rarely required and are a quick, simple process using the tool provided. Rollers feature oil bath lubrication and sealed bearings.

RT•50 Rubber Track Undercarriage

Specifications:

Undercarriage width:	60 in./1524 mm
Undercarriage height:	29 in./736 mm
Undercarriage length:	75 in./1905 mm
Undercarriage weight:	1,500 lb/682 kg
Track width:	15 in./381 mm
Track length (on ground):	59 in./1499 mm
Track weight (each):	150 lb./68 kg
GVWR:	6,000 lb/2722 kg
Carrying Capacity:	approx. 4,600 lb./2090 kg
Ground Pressure at GVWR:	3.4 psi/23.8 kPa
Ground Contact Area:	1,770 in. ² /1.14 m ²
Maximum HP Input:	50 hp/37.3 kW
Maximum Continuous Hydraulic Pressure:	3,000 psi/20 670 kPa
Drive System:	Hydrostatic direct-drive with low-speed/high torque motors
Drive Type:	Internal positive
Track construction:	Proprietary-molded around a high-tensile strength chord
Suspension:	Dual axle, rubber torsion
Rollers:	Twenty-four all-rubber wheels. Wheel bearings are sealed with oil-bath lubrication.
Track Adjustment:	Tensioner on drive sprocket, using tool supplied.



Comparative Specifications - ASV Undercarriages

	RT•30	RT•50	RT•70	RT•100	RT•100D	RT•120
U/C width (in/mm):	46 / 676	60 / 1524	66 / 1676	69 / 1753	69 / 1753	84 / 2134
U/C length (in/mm):	68.5 / 1740	75 / 1905	102 / 2591	100 / 2540	100 / 2540	120 / 3050
Track width (in/mm):	10.75 / 1397	15 / 381	18 / 475	18 / 475	18 / 475	24 / 609
Carrying capacity (lb/kg):	2000 / 907	4600 / 2090	4500 / 2040	6000 / 2722	6000 / 2722	7500 / 3402
Max. input power (hp/kW):	30 / 22.4	50 / 37.3	70 / 52	110 / 82	110 / 82	125 / 93
Drive system:	Hyd. direct	Hyd. direct	Hyd. 2:1 chain drive	Planetary	Hyd. direct	Planetary

ASVRT50
August, 2002

ASV Inc.
 A Caterpillar Affiliate
 840 Lily Lane
 P.O. Box 5160
 Grand Rapids, MN 55744
 Phone: (800) 346-5954
 Fax: (218) 327-2376
www.asvi.com