

RC-60

TURF EDITION™

Posi-Track™

Rubber Track Loader



The ASV RC-60 Turf Edition is a special version mid-sized rubber track loader that offers exceptional power, performance and an outstanding list of leading-edge features. It includes special green smooth rubber tracks designed specially for use on golf courses, parks and other fine turf surfaces.

The RC-60 Turf Edition gives you optimal traction and stability for working more productively in a wide

range of conditions. Ground pressure under the RC-60's 15-inch wide rubber tracks is only 3.1 psi. The track's special smooth surface lets you travel and work on surfaces like turf without leaving a trace.

The RC-60 is powered by the 2.2 liter Caterpillar® 3024CT turbo-charged diesel engine. With 60 hp, 144 ft-lb of peak torque and no derating below 9,840 feet, the RC-60 is the ideal solution for tackling

demanding jobs in virtually every environment.

The RC-60 is designed to lift and place large loads with a rated operating capacity of 1,900 lb (50% tipping load). Loader arms feature a new efficient, robust design similar to ASV's larger machines. The RC-60 also comes standard with a selectable self-leveling feature that makes lift and load tasks easier and more productive.

Horsepower: 60 HP / 44.7 kW

Operating Weight: 6,200 lb / 2812 kg

Ground Pressure: 3.1 psi / 21.4 kPa



A powerful low-impact mid-sized loader designed for RC-60 Rubber Track Loader,



New Turf-friendly Rubber Tracks

Smooth rubber tracks set the ASV RC-60 Turf Edition apart from all other equipment. These unique patent-pending tracks enable the RC-60 to work hard in tough conditions, yet make it virtually impossible to scuff or damage sensitive turf surfaces. That gives you the best of both worlds - excellent traction and minimal impact on manicured surfaces.

Twenty-four rubber wheels distribute the machine weight evenly over the two 15-inch wide rubber tracks.

As a result, there's only 3.1 psi ground pressure - *about half the ground pressure of a person on foot*. This lightweight footprint reduces soil compaction and helps prevent damage to anything underground such as root systems and water lines.

An internal positive drive system uses hydrostatically-driven sprockets with free-turning rollers to engage drive lugs inside the track. There is no steel inside ASV rubber

tracks. As a result, operation is smooth, quiet and with much less friction than on most other rubber track loaders that use steel inside the track.

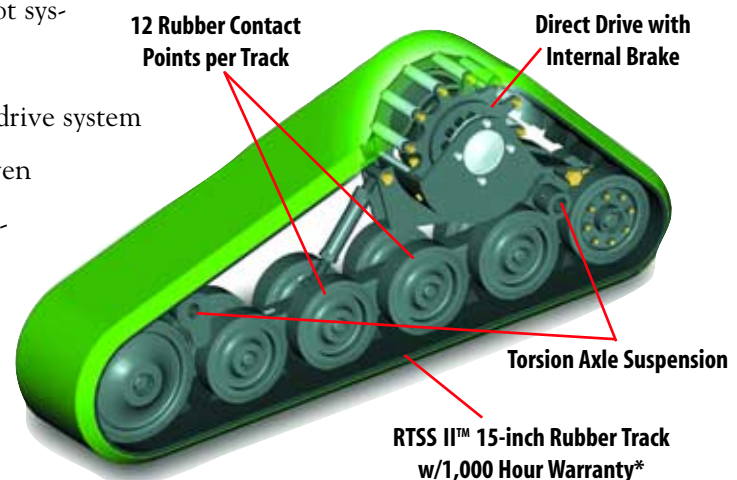

ed for turf professionals. Turf Edition

Torsion axle suspension of the undercarriage is another ASV exclusive. Suspension helps maximize contact with the ground for better traction and stability. It also gives a much smoother ride that is better for the operator, better for load-retention and easier on the machine.

Easy, Comfortable Operation

The RC-60's operator station is designed for comfort and control. For such a compact machine, the RC-60 offers a surprisingly roomy and comfortable operator station. No foot controls mean plenty of leg room. And for work in tight and confined areas, the RC-60 offers excellent all-around visibility.

Ergonomic controls include pilot-operated implement and propel levers. A full spectrum of gauges and switches are conveniently located in the heads-up position for easy view and reach. Safety features include full ROPS/FOPS canopy, lap bar, comfortable seat belt and brake. Standard and deluxe cab enclosures with sound insulation are also available.

Powerful, Reliable Powertrain

The RC-60 Turf Edition is powered



by the Caterpillar® 3024CT - a tough, reliable 2.2 liter 4-cylinder turbocharged diesel engine with high output, low exhaust and excellent performance at higher altitudes.

The Posi-Power Control™ system is an integral part of the RC-60's powertrain. PPC is a power management system that lets you work the RC-60 to its fullest potential as it automatically shifts the hydrostat to match available engine horsepower. With the Posi-Power system, it's virtually impossible to stall the engine. This allows novices to become efficient quickly and lets seasoned profession-

als maximize productivity.

Attachments for Every Application

The RC-60 comes ready to take on most existing skid steer attachments with its industry-standard quick attach interface. For optimum production, stability and compatibility, choose from ASV's line of performance-matched Posi-Tool™ attachments. They include augers, buckets, rakes, mowers, sod-laying equipment and many more.

* See your authorized ASV Dealer for complete details of the ASV machine and track warranties. These warranties may differ outside of North America and are subject to change without notice.

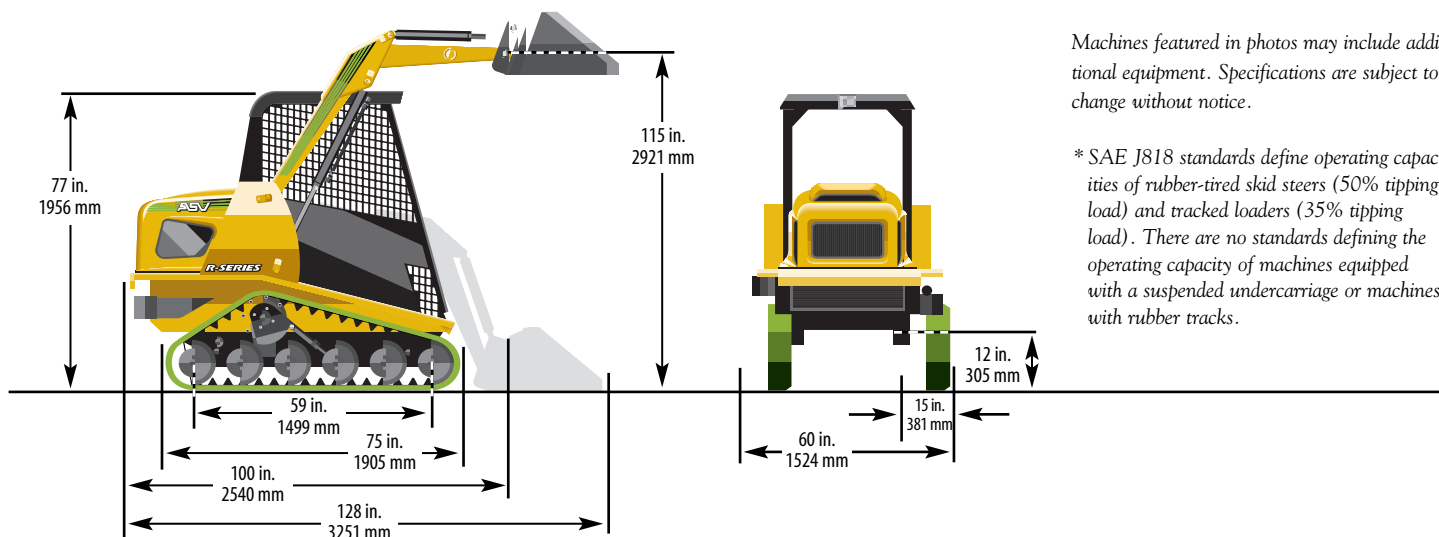

Machines featured in photos may include additional equipment. Specifications are subject to change without notice.

*SAE J818 standards define operating capacities of rubber-tired skid steers (50% tipping load) and tracked loaders (35% tipping load). There are no standards defining the operating capacity of machines equipped with a suspended undercarriage or machines with rubber tracks.

Machine Weight

Operating weight:	6,200 lb. / 2812 kg.
Shipping weight, w/out bucket:	5,500 lb. / 2495 kg.
Ground pressure:	3.1 psi / 21.4 kPa

Track Specifications

Track width:	15 in. / 381 mm
Track length, on ground:	59 in. / 1499 mm
Ground contact area:	1,770 in. ² / 1.14 m ²

Auxiliary Hydraulic Pump

Flow, maximum:	17.4 gpm / 65.9 lpm
Pressure:	3,000 psi / 20 670 kPa

Engine

Type (diesel, turbocharged):	Cat 3024CT
Displacement:	134 in. ³ / 2.2 L
Gross power @ 2800 rpm:	60 hp / 44.7 kW
Torque, peak:	140 ft-lb / 190 Nm

Operating Specifications

Tipping load:	3,800 lb. / 1724 kg
Operating capacity 50% tip load*:	1,900 lb. / 862 kg
Operating capacity 35% tip load*:	1,330 lb. / 603 kg
Travel speed, max.:	8 mph / 13 kmh

Service Refill Capacities

Fuel tank:	15 gal. / 56.8 L
Hydraulic tank:	8 gal. / 30.3 L
Engine coolant:	2 gal. / 7.5 L
Engine oil, inc. filter:	2.8 gal. / 10.6 L

Standard Features

- Air cleaner, dual-stage
- Alternator, 55-amp
- Attachment control, elect.
- Auxiliary hydraulics
- Battery, 770 CCA
- Brake, parking
- Bucket controls, pilot hyd.
- Drive control, pilot hyd.
- Electrical system, 12-volt
- Engine, diesel, Cat 3024CT, turbocharged
- Final drive, direct hydrostatic
- Fuse box, automotive type
- Gauges:
 - fuel level
 - hour meter
 - slope indicator
- Heater, engine block
- Hitch receiver
- Ignition switch, key
- Interior dome light
- Lap bar/arm rest
- Loader arms
- Operator presence switch
- Posi-Power Control (PPC)
- Quick-attach, manual
- Quick-connect auxiliary hydraulic fittings
- ROPS/FOPS canopy
- Rubber track undercarriage
- Screened engine compartment
- Throttle, hand-operated
- Tie-down loops, front/rear
- Transmission, hydrostatic
- Seat belt, two-inch wide
- Self leveling, selectable
- Working lights, halogen:
 - four front, fixed
 - one rear, adjustable
- Warning lights:
 - coolant temp
 - engine oil pressure
 - hot hydraulic oil
 - low battery
- Wiring - pre-installed for all accessory switches

Options

- Air conditioner/heater
- Back-up alarm
- Beacon, rotating
- Brushguard
- Cab enclosures
- Case-style controls
- Front door
- Heater, cab
- Horn
- Lift points, bolt-on
- Seat belt, three-inch wide
- Side windows w/sliding glass
- Sound insulation
- Track tensioner, grease
- Window, rear, glass
- Wiper, front door

